

FORMED LONGITUDINAL JOINT FOR CRCP OR CRCR
(constructed in more than one lane width in one operation)

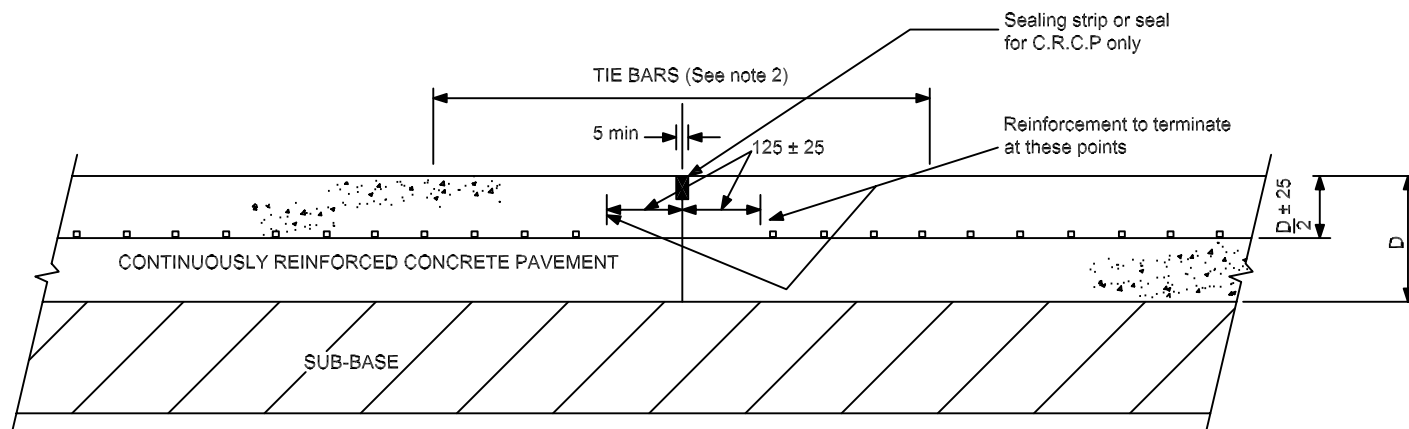

CRCP or CRCR
BUTT TYPE CONSTRUCTION JOINT
(between separately constructed slabs)

NOTES

1. ALL DIMENSIONS ARE IN MILLIMETRES UNLESS OTHERWISE STATED.
2. Tie bars shall be placed equally about the joint + 50 at the same spacing as and adjacent to the transverse reinforcement. Protective coating to be applied to the centre 150 (min) of tie bars.

TIE BARS		
Dia	Length L	Grade BS 4449
12	1000	250
12	750	460
16	600	460
20	500	460